

Republic of the Philippines
Department of Trade and Industry
CENTER FOR INTERNATIONAL TRADE EXPOSITIONS AND MISSIONS
Golden Shell Pavilion, Roxas Blvd. Cor. Gil Puyat Ave., Pasay City

Solicitation No.: CITEM-2021-0022

REQUEST FOR QUOTATION
(NEGOTIATED PROCUREMENT – SMALL VALUE PROCUREMENT)

The Center for International Trade Expositions and Missions (CITEM) invites all interested parties to submit quotation for:

FABRICATION OF THE FOLLOWING CITEM COVID PREVENTION BARRIER AND PARTITIONS:

QUANTITY	UNIT	DESCRIPTION
85	units	A. Desk Module Partition (see Details) - 1.94 SQ.M. 6mm Clear Acrylic with screw and rubber washer
1	set	B. Lobby Entrance Screen Guard (see Details) - 2.80 SQ.M. 6mm Clear Acrylic with suction cups/pads base
13	units	C. Meeting Room Foldable Screen Guard (see Details) - 0.86 SQ.M. 6mm Clear Acrylic with suction cups/pads base
1	set	D. Reception Counter Barrier (see Details) - 2.58 SQ.M. 6mm Clear Acrylic with suction cups/pads base

(Please see attached Specifications for more details.)

Approved Budget : **PHP 639,000.00**
Deadline of Submission of Eligibility Documents and Financial Bid : **19 April 2021, 05:00PM**
Opening of Bids : **20 April 2021, 02:00PM**

Conduct of *Opening of Bids* shall be held virtually thru Microsoft Teams or Zoom and shall be open to all prospective bidders. Link of the Opening of Bids may be requested through the BAC Secretariat at citembac@citem.com.ph.

The *Notice of Award* shall only be issued to the lowest calculated bidder who has complied with the following documentary requirements below, submitted in an enclosed, sealed and properly labeled envelope or compressed folder:

Eligibility Documents (1st Envelope / Compressed Folder)

- Mayor's Permit for the current year or for individuals, BIR Certificate of Registration**
Expired Mayor's permit with Official Receipt of renewal application shall be accepted as alternate documentary document during community quarantine or similar restrictions declared, in accordance with GPPB Resolution 09-2020. However, a valid Business or Mayors permit must be submitted after award of contract but before payment.
- Valid PhilGEPS Registration Number (evidenced by a certificate or screen shot)**
PhilGEPS Certificate of Platinum Membership may be submitted in lieu of Mayor's Permit and PhilGEPS Registration Number.
- Latest Income/Business Tax Return**
- Notarized Omnibus Sworn Statement**
Unnotarized Omnibus Sworn Statement subject to compliance therewith after award of contract before payment shall be accepted as alternate documentary requirement during community quarantine or similar restrictions declared, in accordance with GPPB Resolution 09-2020.
- Notarized Special Power of Attorney, Notarized Secretary's Certificate or Board/Partnership Resolution for partnership, corporation, cooperative, or joint venture, whichever is applicable**
Unnotarized Special Power of Attorney or Unnotarized Secretary's Certificate or Board/Partnership Resolution are likewise accepted in accordance with ARTA Advisory No. 01 series of 2020 on the Advisory for the Adoption of Fast-Track Measures during the COVID-19 State of Calamity.

Financial Bid (2nd Envelope / Compressed Folder)

- Quotation using the attached Request for Quotation (RFQ) Form duly signed by the authorized representative.**

Bidders shall submit these documents, on the above stated date and time, either on the following:

- Physical Submission at the CITEM Office, Golden Shell Pavilion, Roxas Blvd. cor. Gil Puyat Ave., Pasay City, or
- As highly encouraged, online submission to the BAC Secretariat through email at citembac@citem.com.ph. A password protection maybe inflicted in the compressed folders to ensure security of the documents. The password must be disclosed an hour before the date and time of the Opening of Bids indicated above.

CITEM-BAC reserves the right to reject any or all bids disadvantageous to, waive any formality or accept such bids as may be considered advantageous to the government. Further, CITEM-BAC assumes no obligation whatsoever to compensate or indemnify the bidders for expenses or losses that may be incurred in participating in this bidding.

For inquiries, please contact the CITEM Bids and Awards Committee Secretariat, at telephone no. (02) 8-831-2201 local 309/294 or email at citembac@citem.com.ph.

ATTY. ANNA GRACE I. MARPURI
Chairman, Bids and Awards Committee



CENTER FOR INTERNATIONAL TRADE EXPOSITIONS AND MISSIONS
Golden Shell Pavilion, Roxas Blvd. Cor. Sen. Gil Puyat Avenue, Pasay City
Tel.: (632) 8-831-2201 local 309/294 E-mail: citembac@citem.com.ph

REQUEST FOR QUOTATION

- Shopping with ABC of Php 50,001 and above
 Lease of Real Property and Venue
 Small Value Procurement with ABC of Php 50,001 and above
 Others: _____

Date: 08 April 2021

Company Name: _____
Address: _____
Contact No.: _____

RFQ No.: 2021-0022

Gentlemen:

Please quote hereunder your lowest possible price(s) for the following article(s)/work(s) which are urgently needed by this office. It is requested that the quotation be sealed, signed, and stamped in an envelope and submitted to CITEM BAC.

Schedule of Opening of Bids: 20 April 2021 **Time:** 2:00 PM **Venue:** Zoom

FABRICATION OF THE FOLLOWING CITEM COVID PREVENTION BARRIER AND PARTITIONS

QTY	UNIT	ARTICLE / WORK / DESCRIPTION / SPECIFICATION	UNIT PRICE	AMOUNT
85	units	A. Desk Module Partition (see Details) - 1.94 SQ.M. 6mm Clear Acrylic with screw and rubber washer <i>(see attached Specifications more details)</i>		
1	set	B. Lobby Entrance Screen Guard (see Details) - 2.80 SQ.M. 6mm Clear Acrylic with suction cups/pads base <i>(see attached Specifications more details)</i>		
13	units	C. Meeting Room Foldable Screen Guard (see Details) - 0.86 SQ.M. 6mm Clear Acrylic with suction cups/pads base <i>(see attached Specifications more details)</i>		
1	set	D. Reception Counter Barrier (see Details) - 2.58 SQ.M. 6mm Clear Acrylic with suction cups/pads base <i>(see attached Specifications more details)</i>		
APPROVED BUDGET FOR THE CONTRACT: <u>PHP 639,000.00</u> DEADLINE OF SUBMISSION OF ELIGIBILITY DOCUMENTS AND FINANCIAL BID: <u>19 April 2021, 05:00PM</u>				

Terms and Conditions:

- 1) Delivery period: _____ working days upon acceptance of Purchase/Job Order.
- 2) Bid price must be **Inclusive of Value Added Tax**.
- 3) Payment will be processed after receipt of invoice. Other terms of payment will be based on the Contract agreed by the Purchaser and Supplier.
- 4) Any alterations, erasures or overwriting shall be valid only if they are signed or initialed by the bidder or his/her authorized representative.
- 5) Required documents, if any, must be submitted within 3 Days after receipt of notice.

The CITEM-BAC reserves the right to reject any or all bids offer and waive any defects therein and accept bid/s it may consider advantageous to the government.

ATTY. ANNA GRACE I. MARPURI
BAC Chairman

TO: CITEM Bids and Awards Committee:

Per your request, I/we have indicated the prices of the above-mentioned article(s)/work(s) on the unit price/amount column above. I/We also certify that we have read, understood, and shall conform with the terms and conditions of this requirement.

Date Submitted

Signature over printed name of the Authorized Company Representative

Designation: _____

Telephone No(s): _____

Email: _____

BARRIER / PARTITION
LOBBY ENTRANCE SCREEN GUARD
QTY - 1 SET

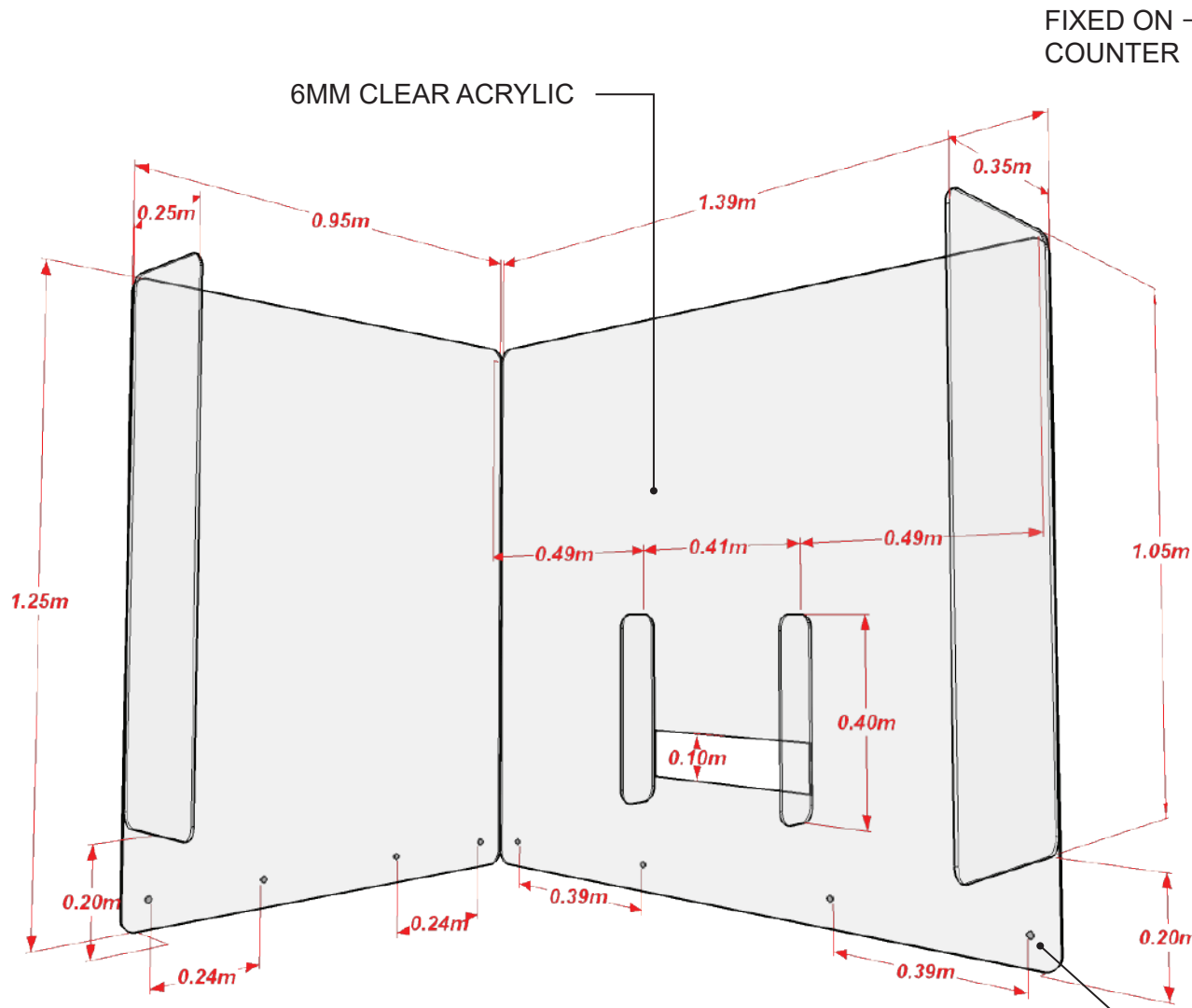

FIXED ON
COUNTER

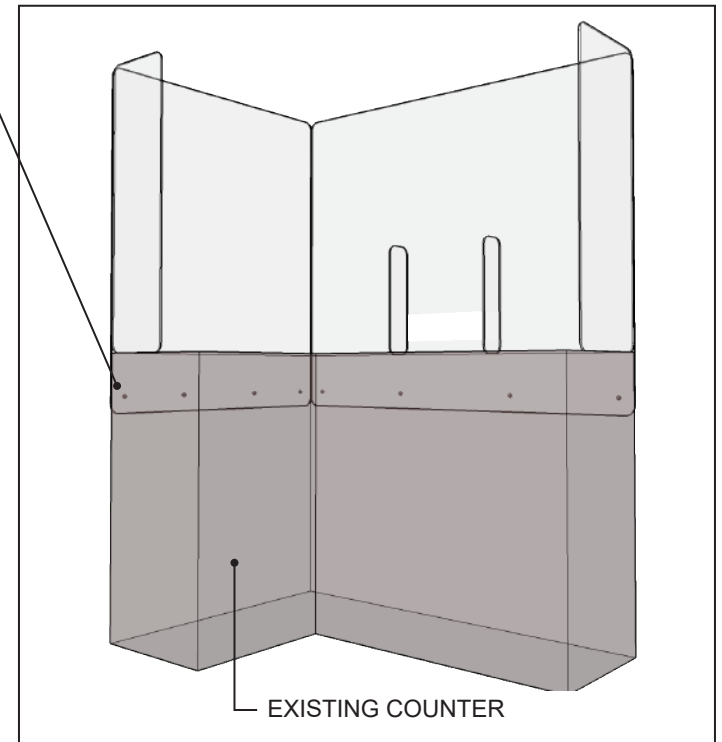

BARRIER / PARTITION
MEETING ROOMS FOLDABLE SCREEN GUARD
QTY - TO BE DETERMINED

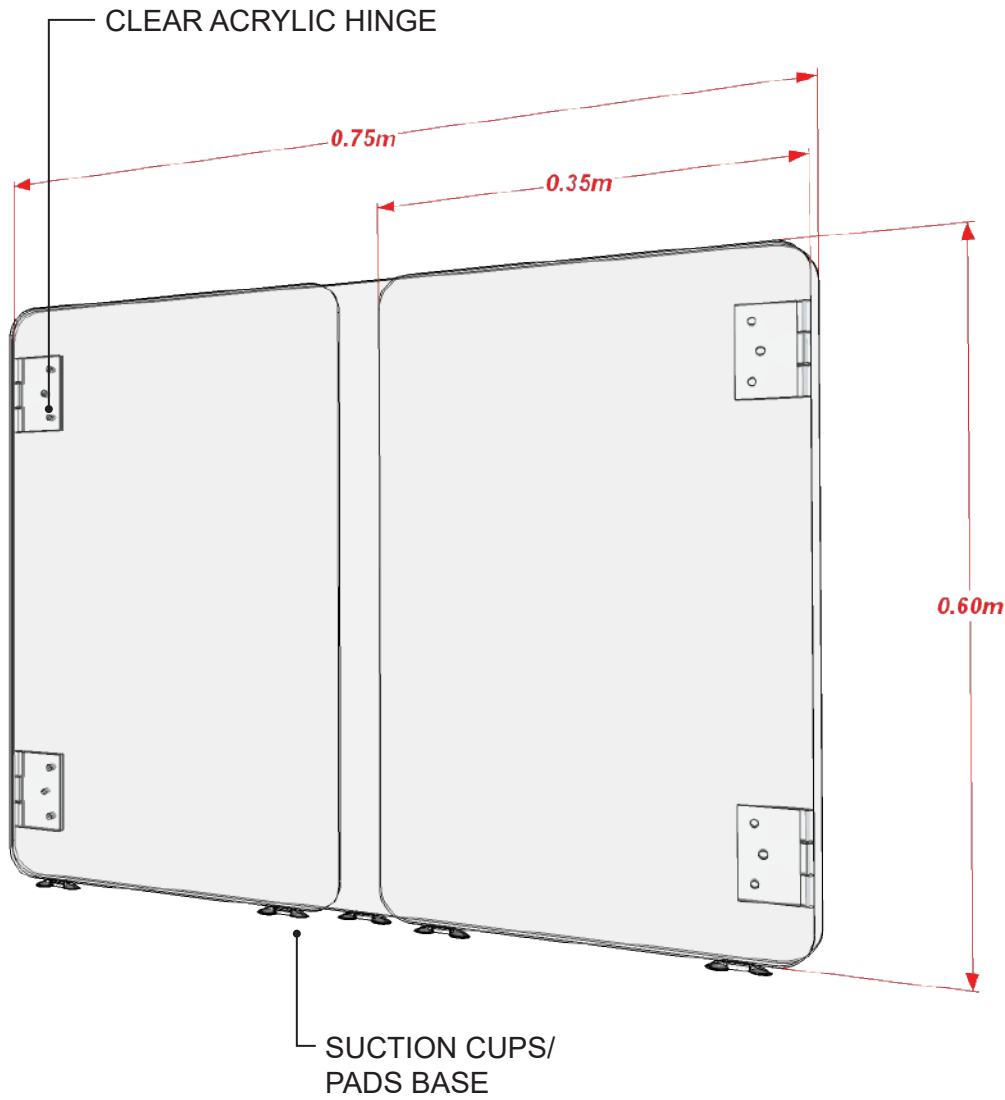
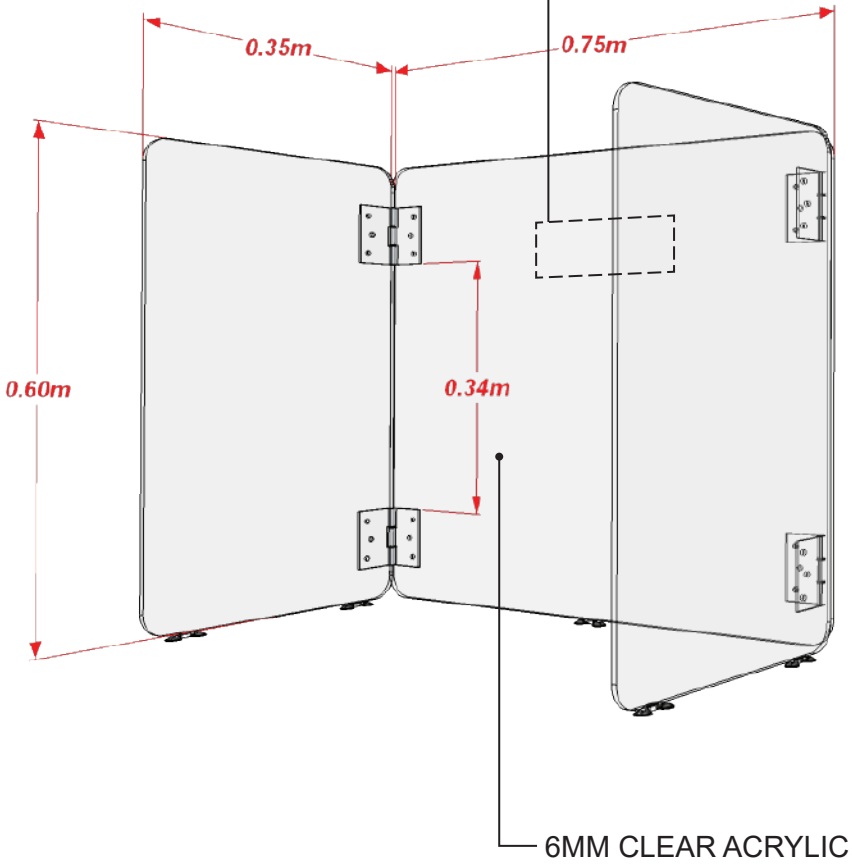

BARRIER / PARTITION
RECEPTION COUNTER BARRIER
QTY - 1 SET

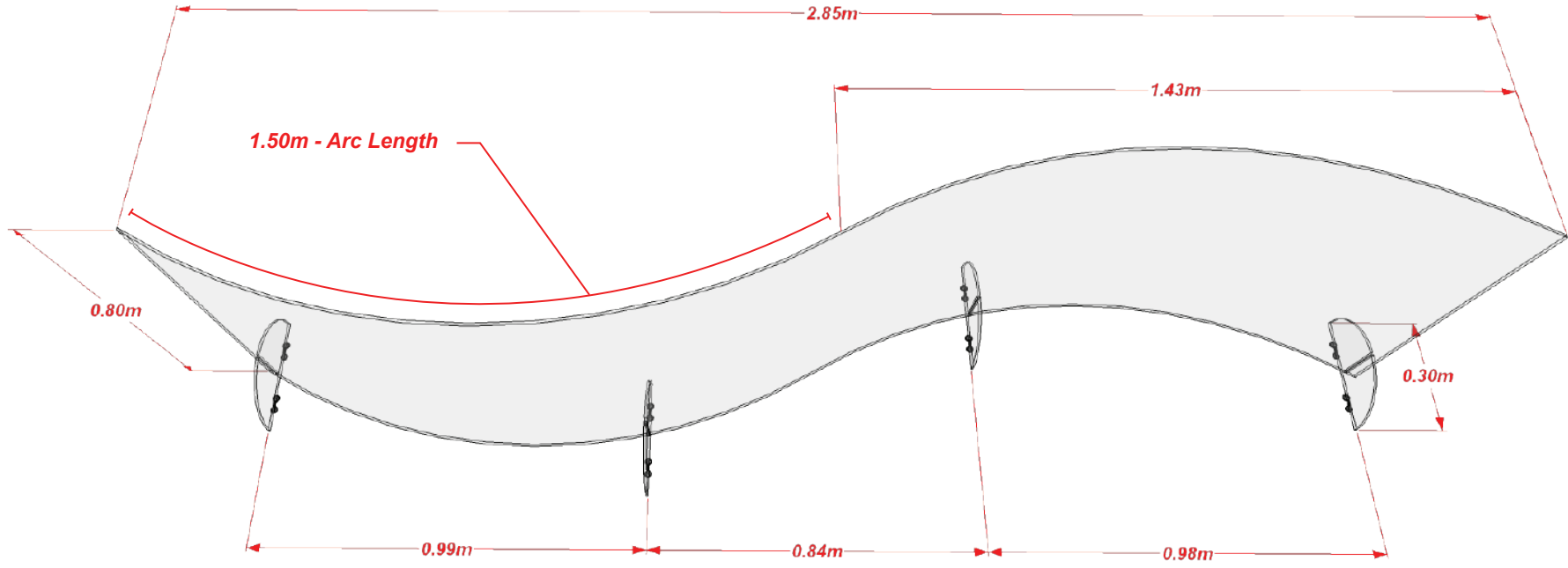
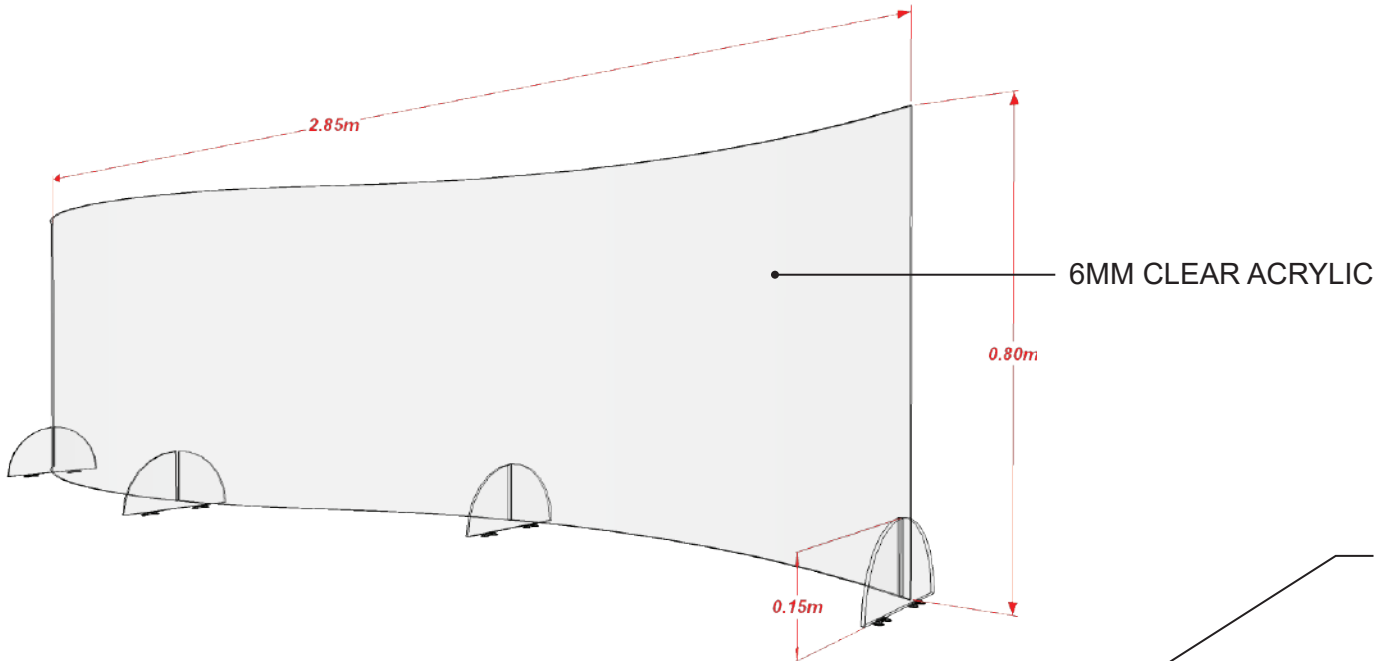

BARRIER / PARTITION
MODULE PARTITION
QTY - TO BE DETERMINED

